

## 模块化快换夹持系统

Modular quick-change clamping system

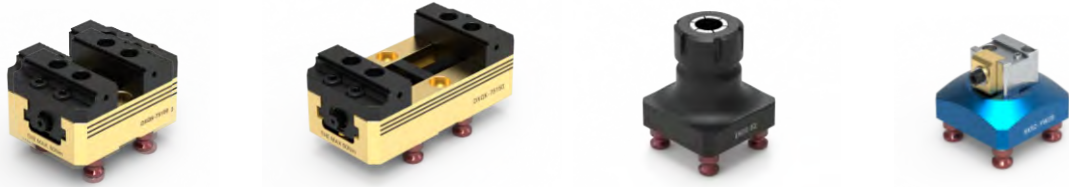

# 模块化工装 Modular tooling



## 节省换装时间

数秒内即可高精度更换夹持工具，固定装置和工件

## 模块化

可组合零点工装种类繁多，可随时扩展

## 简便性

通过拧紧螺钉或快速释放紧固件进行机械夹持

## Save time when changing clothes

High-precision replacement of clamping tools, fixtures and workpieces in seconds

## Modular

There are many kinds of combinable zero-point tooling, which can be expanded at any time.

## Simplicity

Mechanical clamping by tightening screws or quick release fasteners

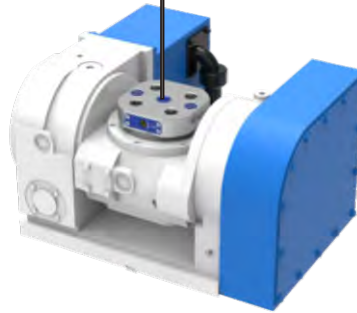

作为机床工作台和夹紧装置之间的接口，NBD的零点快换系统具有多种变换。它可以在3轴，4轴工作台和第5轴的立式和卧式加工中心中普遍使用。

As the interface between the machine tool table and the clamping device, NBD's zero-point quick change system has a variety of transformations. It can be universally used in vertical and horizontal machining centers with 3-axis, 4-axis tables and 5th axis.

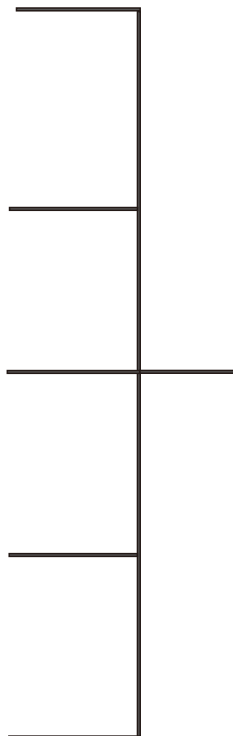

# 四孔定位器 Four hole locator

SLTA52-108

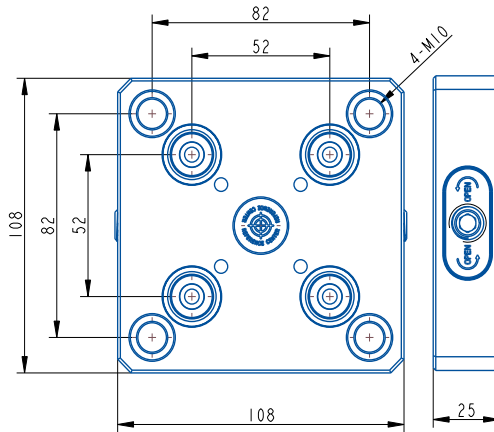

## 描述 Describe

尺寸: 108×108×25mm  
 重复定位: 0.005mm  
 锁紧力: 17KN (4个螺栓)  
 材质: 铝+硬化不锈钢  
 重量: 1.1Kg  
**Size: 108×108×25mm**  
**Repeat positioning: 0.005mm**  
**Locking force: 17KN (4 bolts)**  
**Material: Hard aluminum +steel ring**  
**Weight: 1.1Kg**

SLTA9652-155

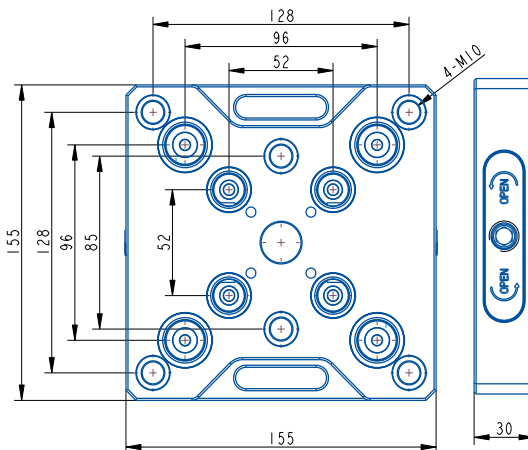

## 描述 Describe

尺寸: 155×155×30mm  
 重复定位: 0.005mm  
 锁紧力: 18KN (4个螺栓)  
 材质: 铝+硬化不锈钢  
 重量: 2.2Kg  
**Size: 155×155×30mm**  
**Repeat positioning: 0.005mm**  
**Locking force: 18KN (4 bolts)**  
**Material: Hard aluminum +steel ring**  
**Weight: 2.2Kg**

# 四孔定位器 Four hole locator

SL96-S155

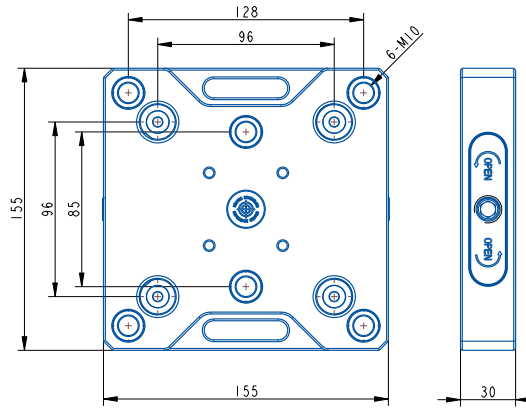

## 描述 Describe

尺寸: 155×155×30mm  
 重复定位: 0.005mm  
 锁紧力: 22KN (6个螺栓)  
 材质: 硬化不锈钢  
 重量: 4.8Kg  
**Size: 155×155×30mm**  
**Repeat positioning: 0.005mm**  
**Locking force: 22KN (6 bolts)**  
**Material: Hardened stainless steel**  
**Weight: 4.8Kg**

SL96-185

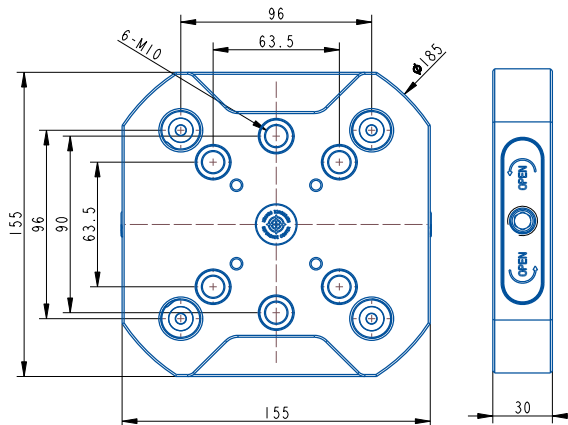

## 描述 Describe

尺寸:  $\Phi 185 \times 30$ mm  
 重复定位: 0.005mm  
 锁紧力: 22KN (6个螺栓)  
 材质: 硬化不锈钢  
 重量: 4.5Kg  
**Size:  $\Phi 185 \times 30$ mm**  
**Repeat positioning: 0.005mm**  
**Locking force: 22KN (6 bolts)**  
**Material: Hardened stainless steel**  
**Weight: 4.5Kg**

SL96-S175

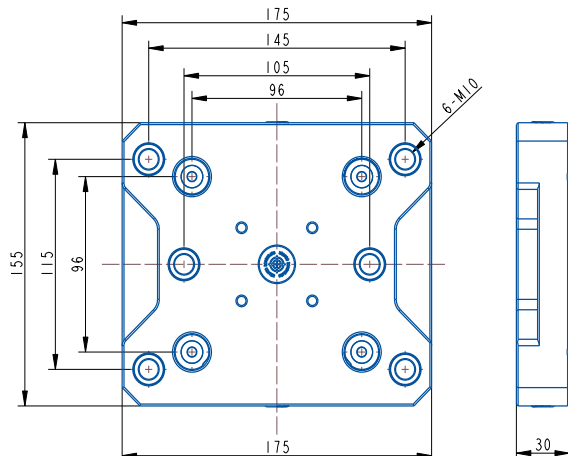

## 描述 Describe

尺寸: 175×155×30mm  
 重复定位: 0.005mm  
 锁紧力: 22KN (6个螺栓)  
 材质: 硬化不锈钢  
 重量: 5Kg  
**Size: 175×155×30mm**  
**Repeat positioning: 0.005mm**  
**Locking force: 22KN (6 bolts)**  
**Material: Hardened stainless steel**  
**Weight: 5 Kg**

# 四孔定位器 Four hole locator

## SL96-200

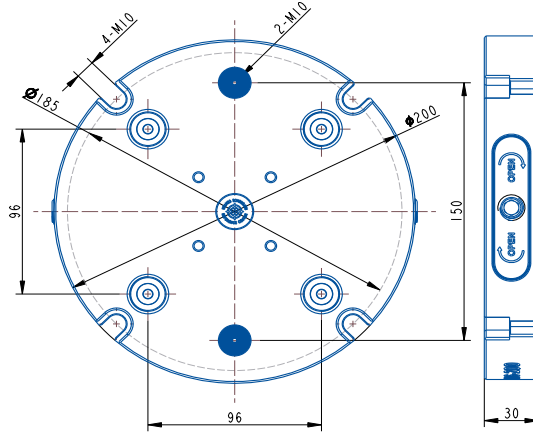

### 描述 Describe

尺寸:  $\Phi 200 \times 30$ mm 重  
重复定位: 0.005mm  
锁紧力: 20KN (2个螺栓)  
材质: 硬化不锈钢  
重量: 6.5Kg  
**Size:  $\Phi 200 \times 30$ mm**  
**Repeat positioning: 0.005mm**  
**Locking force: 20KN (2 bolts)**  
**Material: Hardened stainless steel**  
**Weight: 6.5Kg**

SL96-0090

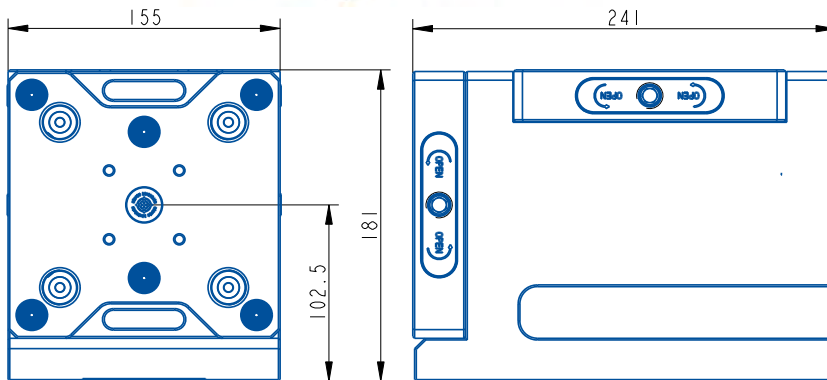

### 描述 Describe

尺寸: 241×181×255mm  
重复定位: 0.005mm  
锁紧力: 22KN  
材质: 硬化不锈钢+铝  
重量: 24Kg  
**Size: 241×181×255mm**  
**Repeat positioning: 0.005mm**  
**Locking force: 22KN**  
**Material: Hardened Stainless Steel + AL**  
**Weight: 24Kg**

SL96-276

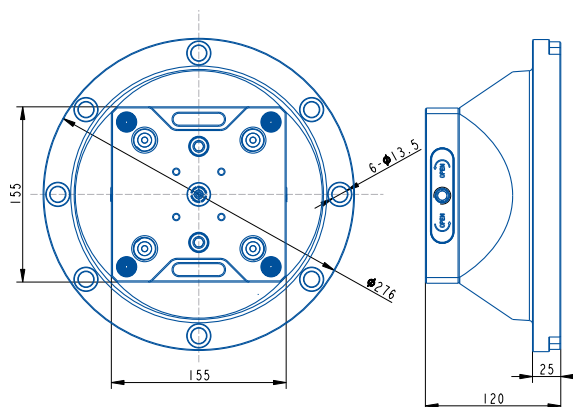

### 描述 Describe

尺寸:  $\Phi 276 \times 120$   
重复定位: 0.005mm  
锁紧力: 22KN (6个螺栓)  
材质: 铝+硬化不锈钢  
重量: 15Kg

**Size:  $\Phi 276 \times 120$**   
**Repeat positioning: 0.005mm**  
**Locking force: 22KN (6 bolts)**  
**Material: Aluminum + Hardened Stainless Steel**  
**Weight: 15Kg**

# 四孔定位器 Four hole locator

SL52-108

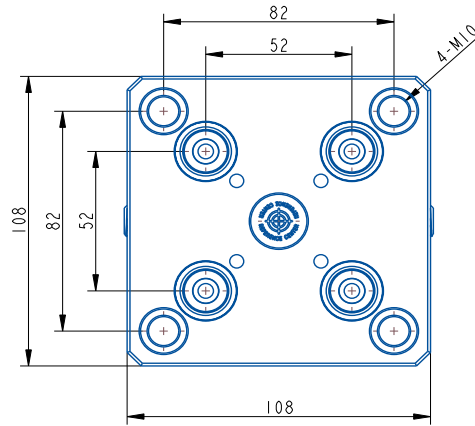

## 描述 Describe

尺寸: 108×108×25mm  
 重复定位: 0.005mm  
 锁紧力: 18KN (4个螺栓)  
 材质: 硬化不锈钢  
 重量: 1.9Kg  
**Size: 108×108×25mm**  
**Repeat positioning: 0.005mm**  
**Locking force: 18KN (4 bolts)**  
**Material: Hardened stainless steel**  
**Weight: 1.9Kg**

SL52-S170

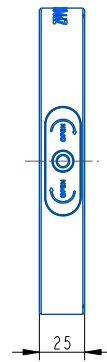
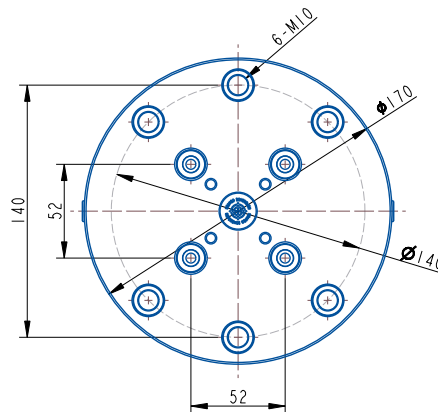

## 描述 Describe

尺寸:  $\Phi 170 \times 125$ mm  
 重复定位: 0.005mm  
 锁紧力: 18KN (6个螺栓)  
 材质: 硬化不锈钢  
 重量: 3.7Kg  
**Size:  $\Phi 170 \times 125$ mm**  
**Repeat positioning: 0.005mm**  
**Locking force: 18KN (6 bolts)**  
**Material: Hardened stainless steel**  
**Weight: 3.7Kg**

SL52-120

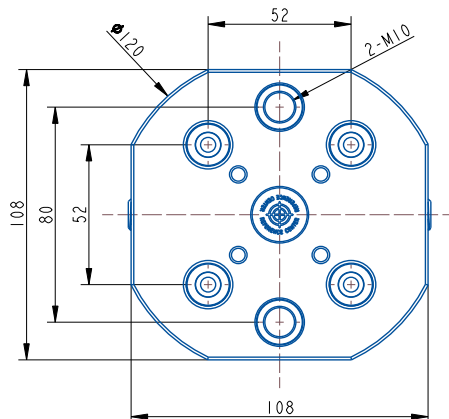

## 描述 Describe

尺寸:  $\Phi 120 \times 25$ mm 重  
 重复定位: 0.005mm  
 锁紧力: 18KN (4个螺栓)  
 材质: 硬化不锈钢  
 重量: 1.8Kg  
**Size:  $\Phi 120 \times 25$ mm**  
**Repeat positioning: 0.005mm**  
**Locking force: 18KN (4 bolts)**  
**Material: Hardened stainless steel**  
**Weight: 1.8Kg**

# 四孔定位器 Four hole locator

## SL52-T96

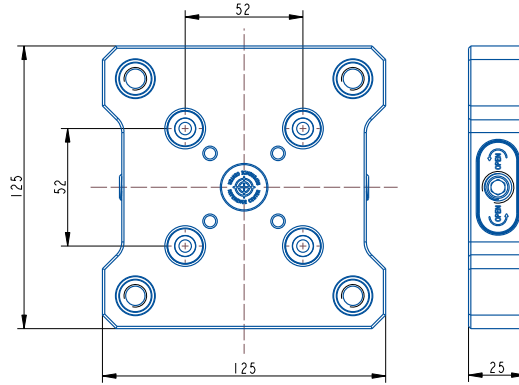

### 描述 Describe

尺寸: 125×125×25mm  
 重复定位: 0.005mm  
 锁紧力: 18KN (4个螺栓)  
 材质: 铝+硬化不锈钢  
 重量: 2.5Kg  
**Size: 125×125×25mm**  
**Repeat positioning: 0.005mm**  
**Locking force: 18KN (4 bolts)**  
**Material: Hardened stainless steel**  
**Weight: 2.5Kg**

## SL52-9096

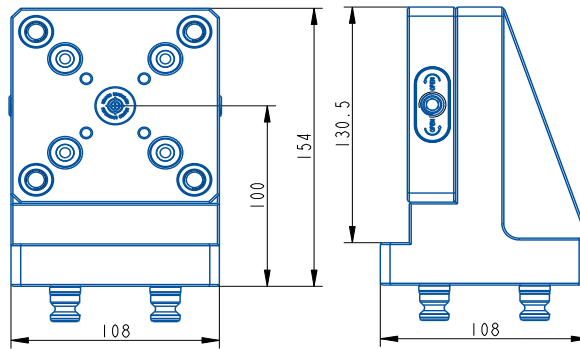

### 描述 Describe

尺寸: 154×108×108mm  
 重复定位: 0.005mm  
 锁紧力: 18KN  
 材质: 铝+硬化不锈钢  
 重量: 4.5Kg  
**Size: 154×108×108mm**  
**Repeat positioning: 0.005mm**  
**Locking force: 18KN**  
**Material: Aluminum + Hardened Stainless Steel**  
**Weight: 4.5Kg**

## SL96-9096

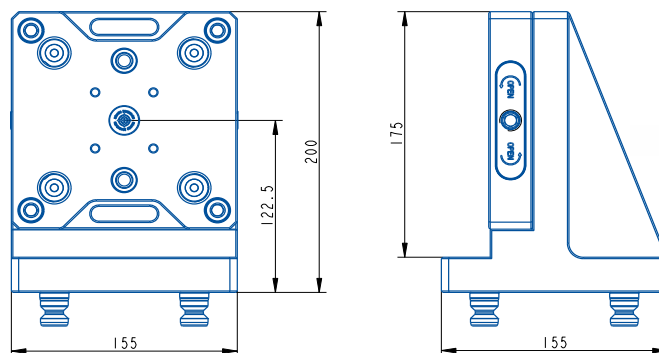

### 描述 Describe

尺寸: 200×155×155mm  
 重复定位: 0.005mm  
 锁紧力: 22KN  
 材质: 铝+硬化不锈钢  
 重量: 9.5Kg  
**Size: 200×150×155mm**  
**Repeat positioning: 0.005mm**  
**Locking force: 22KN**  
**Material: aluminum +hard steel**  
**Weight: 9.5Kg**

# 双工位四孔定位器 Dual station four hole positioner

SL52-210

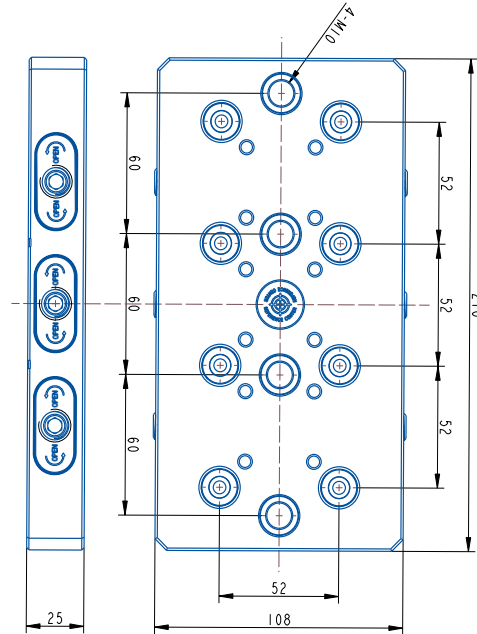

**描述 Describe**

尺寸: 210×108×25mm  
 重复定位: 0.005mm  
 锁紧力: 18KN (4个螺栓)  
 材质: 硬化不锈钢  
 重量: 3.6Kg  
**Size: 210×108×25mm**  
**Repeat positioning: 0.005mm**  
**Locking force: 18KN (4 bolts)**  
**Material: Hardened Stainless Steel**  
**Weight: 3.6Kg**

SL96-340

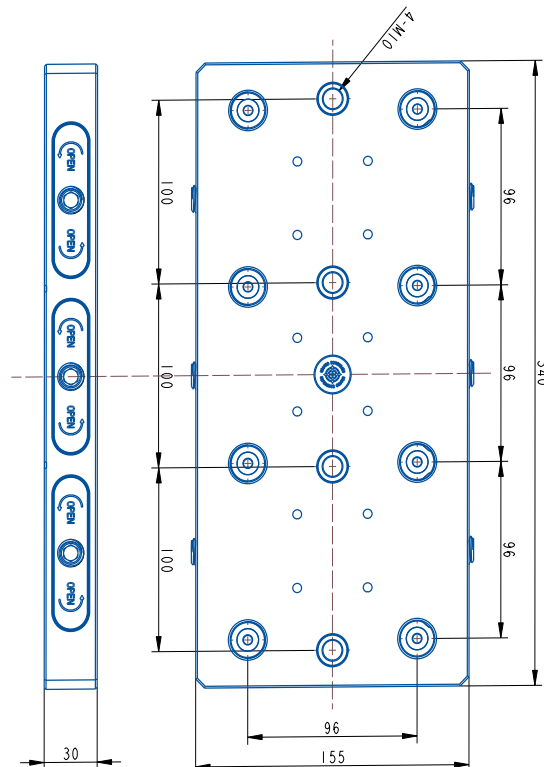
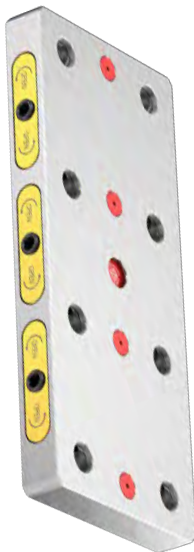

**描述 Describe**

尺寸: 340×155×30mm  
 重复定位: 0.005mm  
 锁紧力: 22KN (4个螺栓)  
 材质: 硬化不锈钢  
 重量: 11.5Kg  
**Size: 340×155×30mm**  
**Repeat positioning: 0.005mm**  
**Locking force: 22KN (4 bolts)**  
**Material: Hardened Stainless Steel**  
**Weight: 11.5Kg**



## 气动四孔定位器

# Pneumatic four-hole positioner

QSL96-155

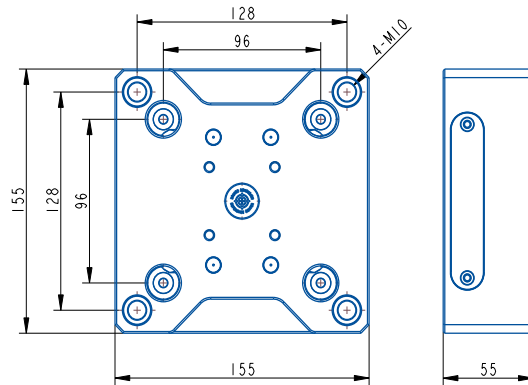

### 描述 Describe

尺寸: 155×155×155mm

重复定位: 0.005mm

材质: 硬化不锈钢

重量: 8.0Kg

**Size: 155×155×155mm**

**Repeat positioning: 0.005mm**

**Material: Hardened**

**Stainless Steel**

**Weight: 8.0Kg**

QSL52-108

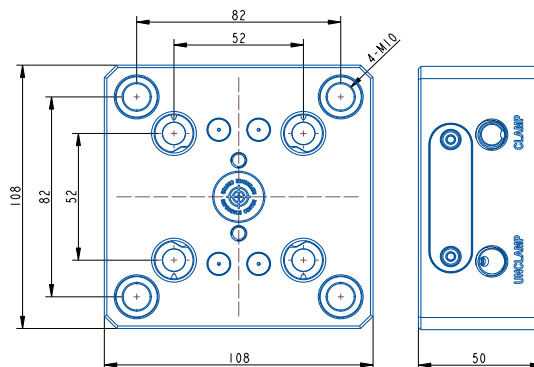

### 描述 Describe

尺寸: 108×108×50mm

重复定位: 0.005mm

材质: 硬化不锈钢

重量: 3.3Kg

**Size: 108×108×50mm**

**Repeat positioning: 0.005mm**

**Material: Hardened**

**Stainless Steel**

**Weight: 3.3Kg**

# 燕尾夹 Dovetail clip

Y W12

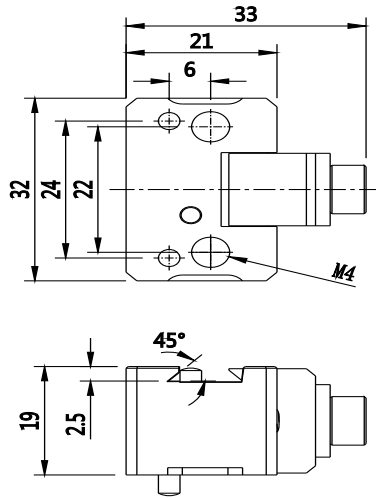

## 描述 Describe

尺寸: 21×32×19mm  
材质: 硬化不锈钢  
夹持范围: 12-25mm  
燕尾深度: 2.54mm  
最大扭矩: 8Nm  
重量: 0.1Kg

**Size: 21×32×19mm**  
**Material: Hardened stainless steel**  
**Clamping range: 12-25mm**  
**Dovetail depth: 2.54mm**  
**Maximum torque: 8Nm**  
**Weight: 0.1Kg**

Y W25

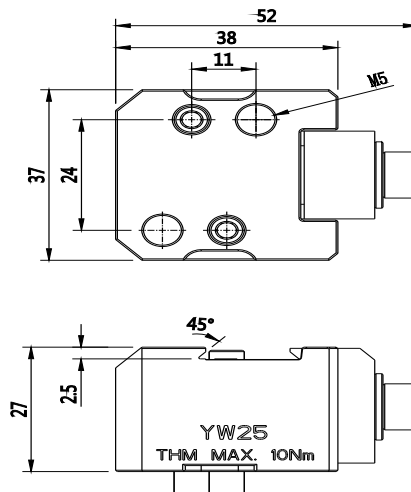

## 描述 Describe

尺寸: 21×32×19mm  
材质: 硬化不锈钢  
夹持范围: 25-70mm  
燕尾深度: 2.54mm  
最大扭矩: 10Nm  
重量: 0.25Kg

**Size: 21×32×19mm**  
**Material: Hardened stainless steel**  
**Clamping range: 25-70mm**  
**Dovetail depth: 2.54mm**  
**Maximum torque: 10Nm**  
**Weight: 0.25Kg**

Y W50

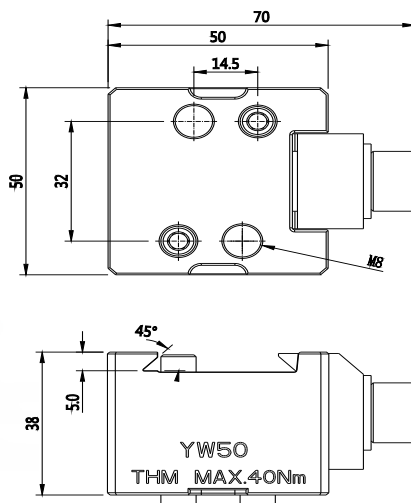

## 描述 Describe

尺寸: 50×50×38mm  
材质: 硬化不锈钢  
夹持范围: 50mm以上  
燕尾深度: 5.08mm  
最大扭矩: 40Nm  
重量: 0.65Kg

**Size: 50×50×38mm**  
**Material: Hardened stainless steel**  
**Clamping range: 50mm or more**  
**Dovetail depth: 5.08mm**  
**Maximum torque: 40Nm**  
**Weight: 0.65Kg**

## 52型燕尾夹 Dovetail clip YW12-52

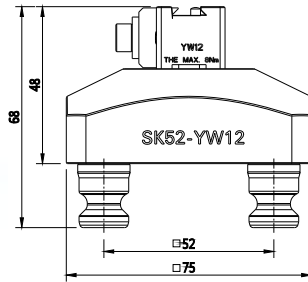
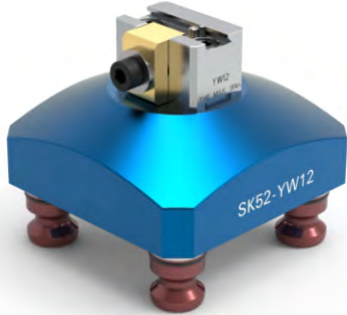

### 描述 Describe

尺寸: 75×75×68mm  
材质: 硬化不锈钢+铝  
夹持范围: 12-25mm  
燕尾深度: 2.54mm  
最大扭矩: 8Nm  
重量: 0.6Kg

**Size: 75×75×68mm**

**Material:**

**Hardened stainless steel+ aluminum**

**Clamping range:**  
12-25mm

**Dovetail depth:**  
2.54mm

**Maximum torque:**  
8Nm

**Weight: 0.6Kg**

## YW25-52

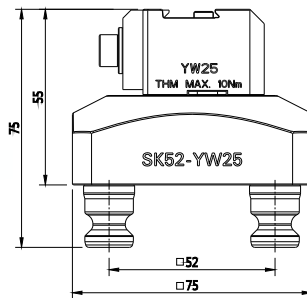
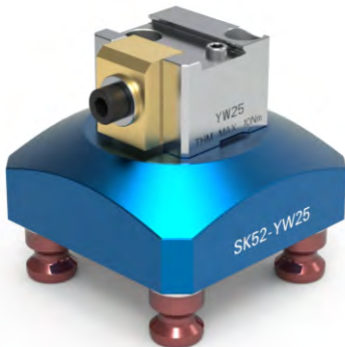

### 描述 Describe

尺寸: 75×75×75mm  
材质: 硬化不锈钢+铝  
夹持范围: 12-25mm  
燕尾深度: 2.54mm  
最大扭矩: 10Nm  
重量: 0.8Kg

**Size: 75×75×75mm**

**Material:**

**Hardened stainless steel + aluminum**

**Clamping range:**  
12-25mm

**Dovetail depth: 2.54mm**

**Maximum torque: 10Nm**

**Weight: 0.8Kg**

## YW50-52

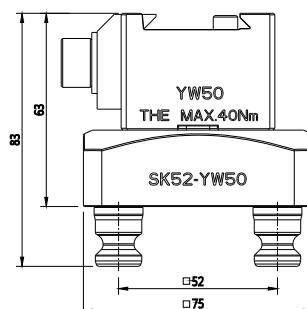
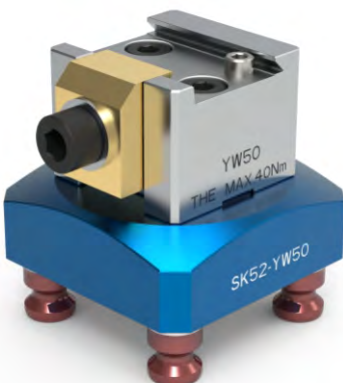

### 描述 Describe

尺寸: 75×75×83mm  
材质: 硬化不锈钢+铝  
夹持范围: 50mm以上  
燕尾深度: 5.08mm  
最大扭矩: 40Nm  
重量: 1.1Kg

**Size:**  
75×75×83mm

**Material:**

**Hardened stainless steel + aluminum**

**Clamping range:**  
50mm or more

**Dovetail depth: 5.08mm**

**Maximum torque:**  
40Nm

**Weight: 1.1Kg**

# 96型燕尾夹 Dovetail clip

## YW12-96

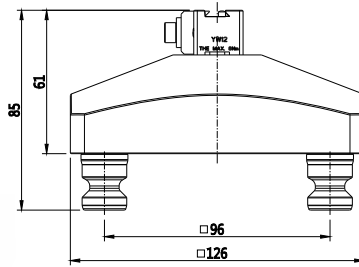
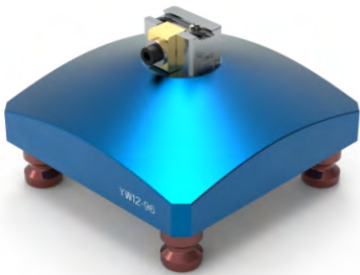

### 描述 Describe

尺寸: 126×126×85mm

材质: 硬化不锈钢+铝

夹持范围: 12-25mm

燕尾深度: 2.54mm

最大扭矩: 8Nm

重量: 1.7Kg

**Size: 126×126×85mm**

**Material: Hardened stainless steel**

**aluminum**

**Clamping range:**

**12-25mm**

**Dovetail depth: 2.54mm**

**Maximum torque: 8Nm**

**Weight: 1.7Kg**

## YW25-96

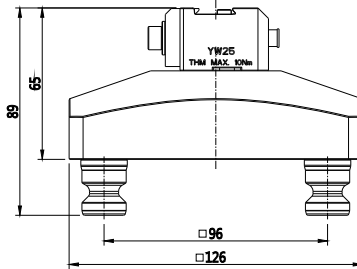
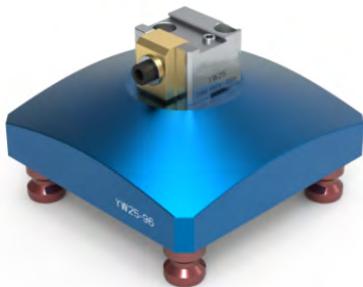

### 描述 Describe

尺寸: 126×126×89mm

材质: 硬化不锈钢+铝

夹持范围: 12-25mm

燕尾深度: 2.54mm

最大扭矩: 10Nm

重量: 2.3Kg

**Size:**

**126×126×89mm**

**Material: Hardened stainless steel +**

**aluminum**

**Clamping range:**

**12-25mm**

**Dovetail depth:**

**2.54mm**

**Maximum torque:**

**10Nm**

**Weight: 2.3Kg**

## YW50-96

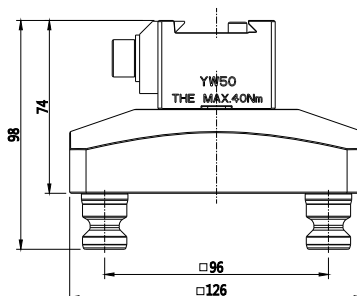
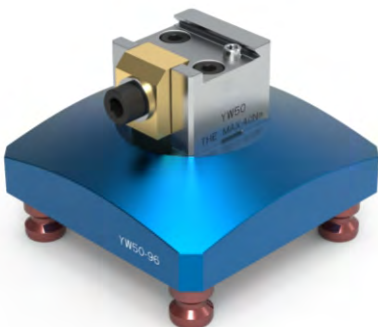

### 描述 Describe

尺寸: 126×126×98mm

材质: 硬化不锈钢+铝

夹持范围: 50mm以上

燕尾深度: 5.08mm

最大扭矩: 40Nm

重量: 2.3Kg

**Size: 126×126×98mm**

**Material: Hardened stainless steel +**

**aluminum**

**Clamping range:**

**50mm or more**

**Dovetail depth: 5.08mm**

**Maximum torque: 40Nm**

**Weight: 2.3Kg**

## 真空吸盘

V247-40

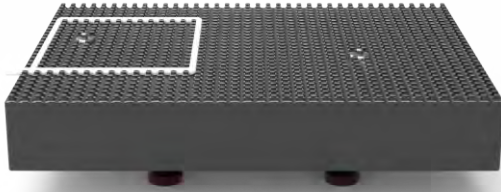

## Vacuum suction cup

### 描述 Describe

尺寸: 247×191×39mm

材质: AL

重量: 5.5Kg

带96拉钉系统

Size:

247×191×39mm

Material: AL

Weight: 5.5Kg

With 96 rivet system

## 真空动力装置



### 描述 Describe

真空动力装置 (VPU)是系统的核心。

真空从这个单一的单元产生、打开和关闭以及监控。压缩空气以 0.65Mpa的压力进入，转换为 28" Hg 的真空功率——等于或优于传统真空泵，并且无需过滤器或冷却剂收集器。它是一种低流量、高水平泵旨在与无孔工件一起使用。最重要的是，它仅消耗 0.02CMM 的空气 (最大真空流量为 0.028CMM)。

**The vacuum power unit (VPU) is the heart of the system.**

**Vacuum is generated, turned on and off and monitored from this single unit. Compressed air enters at a pressure of 0.65Mpa, converting to 28" Hg of vacuum power – equal to or better than conventional vacuum pumps, and without the need for filters or coolant collectors. It is a low-flow, high-level pump designed to work with no Use it with hole workpieces. Most importantly, it only consumes 0.02CMM of air (maximum vacuum flow is 0.028CMM).**

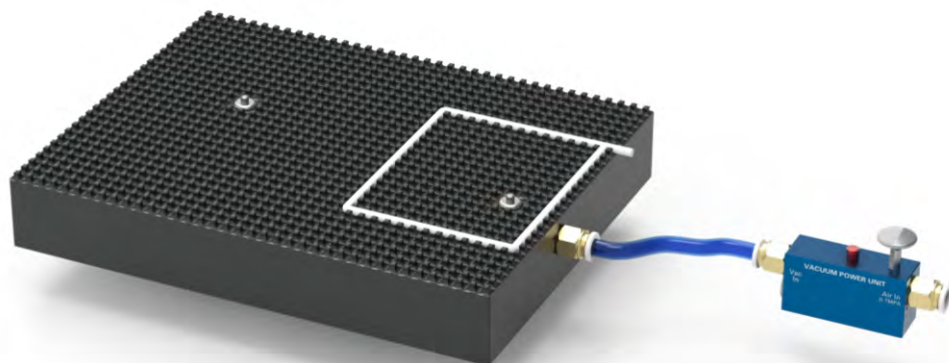

# 三面工装塔 Three-sided tooling tower

## SK52-S160



### 描述 Describe

尺寸:  $\Phi 160 \times 167 \text{mm}$

材质: 铝+钢

重量: 6.8Kg

底部预制96系统拉钉孔，可快速的在零点夹紧系统中进行精确夹紧

**Size:  $\Phi 160 \times 167 \text{mm}$**

**Material: aluminum+steel**

**Weight: 6.8Kg**

The bottom is prefabricated with 96 system rivet holes, which can quickly and accurately clamp in the zero-point clamping system.

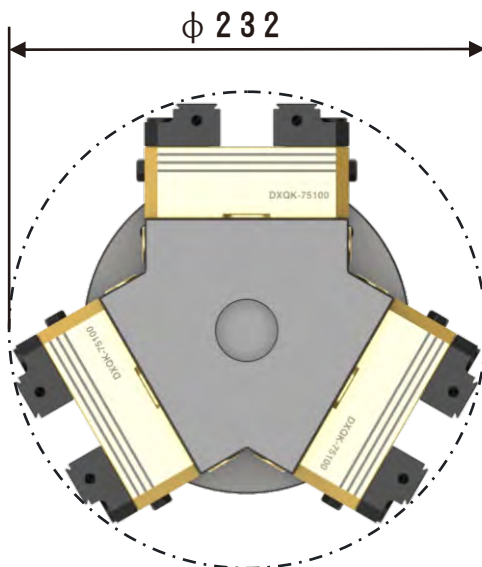

安装三个75100的虎钳

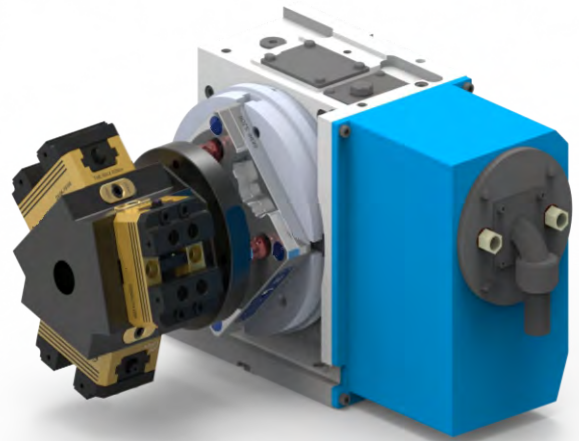

## 四面工装塔 Four-sided tooling tower

迷你型四面工装塔,应用于较小的4轴和5轴机床,保持紧凑空间的同时提高生产率,最多可以安装8个虎钳,使机床可以在无人值守的情况下运行,这样可以最大程度地减少装夹时间,并使作业人员可以操作多台机床。

75-A96



The mini four-sided tooling tower is used in smaller 4-axis and 5-axis machine tools to increase productivity while maintaining a compact space. Up to 8 vises can be installed, allowing the machine tool to operate unattended. This minimizes setup time and allows operators to operate multiple machine tools.

### 描述 Describe

尺寸: 126×126\*200mm

材质: AL

重量: 6.5Kg

**Size:**  
126×126\*200mm  
**Material:** AL  
**Weight:** 6.5Kg

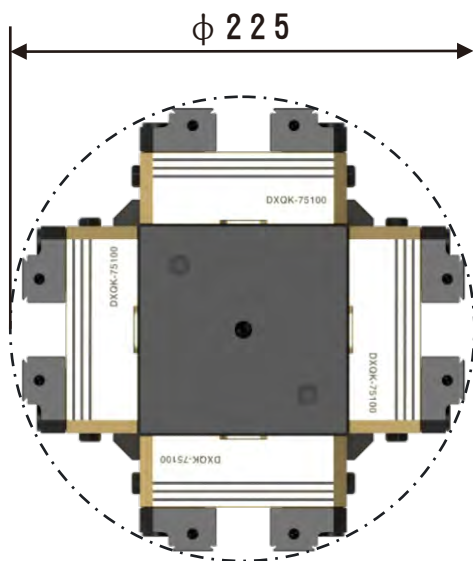

虎钳水平安装

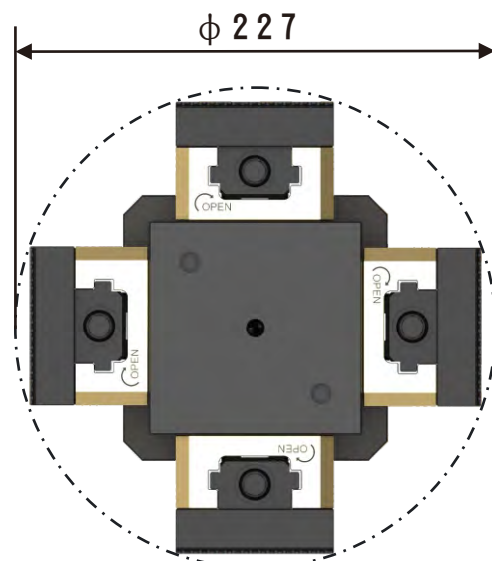

虎钳垂直安装

## 三面金字塔

## Three sided pyramid

高强度，铝制三面金字塔与集成的快换板，增加5轴机床的运行时间。  
减少换刀次数，延长主轴的精度。

SK96-D400

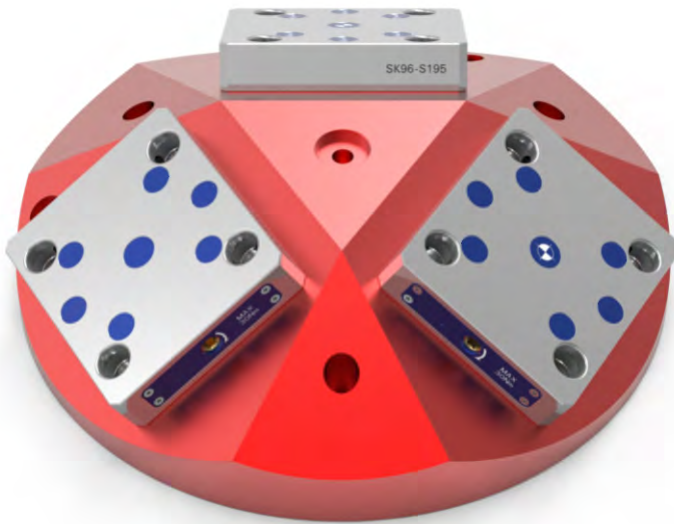

High-strength, aluminum three-sided pyramid with integrated quick-change plates increases uptime on 5-axis machines. Reduce the number of tool changes and extend the accuracy of the spindle.

### 描述 Describe

尺寸:  $\Phi 395 \times 115 \text{mm}$

材质: 铝

重量: 32Kg

角度:  $\angle 30$ 度 适用于倾斜度为 $120^\circ$  或以上的机器。

Size:  $\Phi 395 \times 115 \text{mm}$

Material: aluminum

Weight: 32Kg

Angle:  $\angle 30$  degrees, suitable for inclinations of  $120^\circ$

or above machines.

The bottom is prefabricated with 96 system rivet holes for quick

Precise clamping in zero-point clamping systems

Note: The machine brand and model are required when ordering to ensure the correct mounting hole locations.

底部预制96系统拉钉孔，可快速的在零点夹紧系统中进行精确夹紧

注意：订购时需要机器品牌和型号，以确保安装孔位正确。

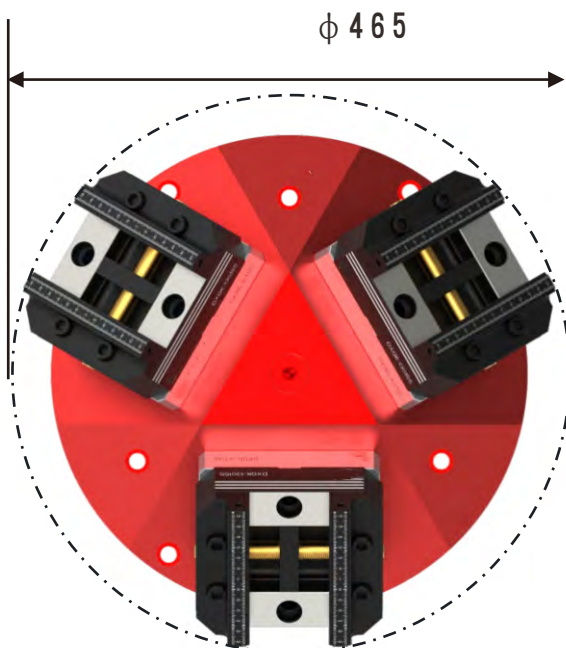

虎钳水平安装

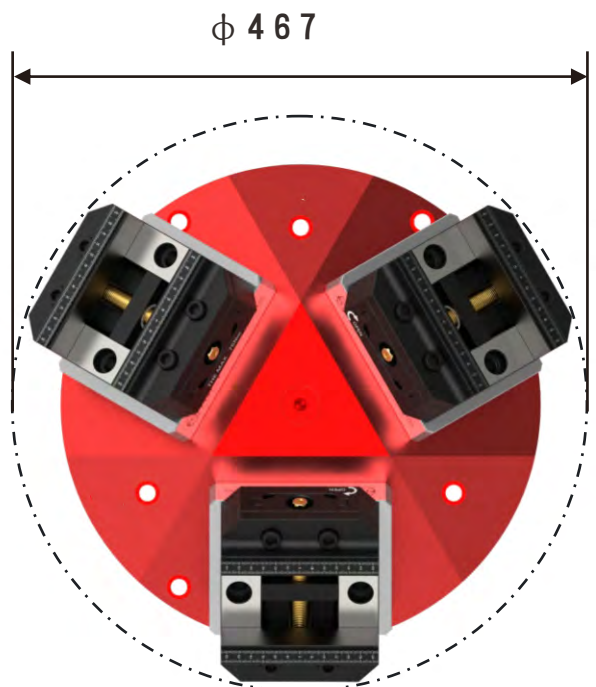

虎钳垂直安装



## 75系列定心虎钳 DXQK-75100T

## Self centering vise



### 描述 Describe

尺寸: 75×100×56mm  
正向夹持范围: 0-41mm  
反向夹持范围: 41-76mm  
钳体宽度: 75mm  
最大扭矩: 60Nm@14KN  
重量: 2.3Kg

**Size: 75×100×56mm**  
**Forward clamping range: 0-41mm**  
**Reverse clamping range: 41-76mm**  
**Clamp body width: 75mm**  
**Maximum torque: 60Nm@14KN**  
**Weight: 2.3Kg**

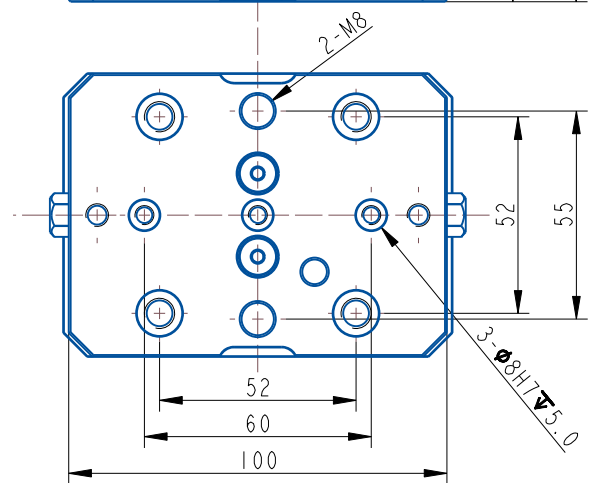
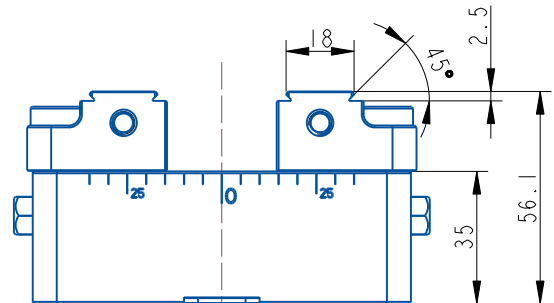

## DXQK-75150T



### 描述 Describe

尺寸: 75×150×56mm  
正向夹持范围: 0-90mm  
反向夹持范围: 41-126mm  
钳体宽度: 75mm  
最大扭矩: 60Nm@14KN  
重量: 3Kg

**Size: 75×150×56mm**  
**Forward clamping range: 0-90mm**  
**Reverse clamping range: 41-126mm**  
**Clamp body width: 75mm**  
**Maximum torque: 60Nm@14KN**  
**Weight: 3Kg**

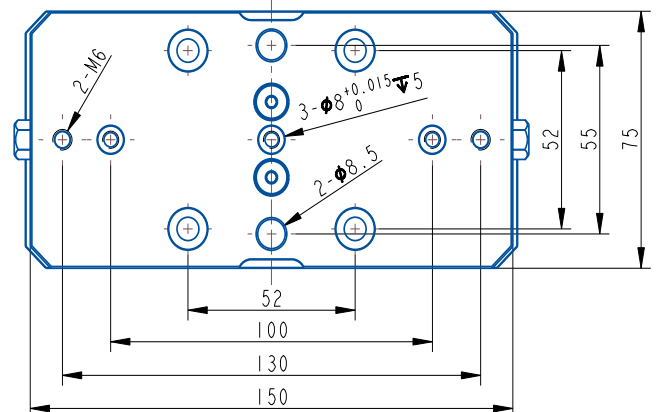
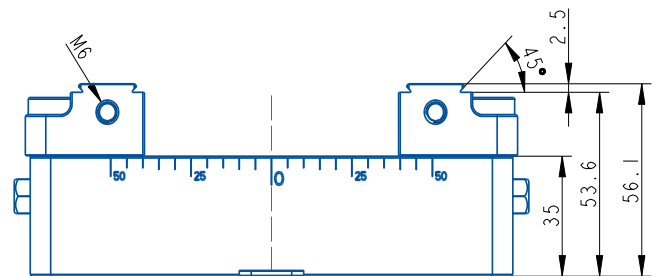

## 75系列定心虎钳 DXQK-75100



### 描述 Describe

尺寸: 75×100×56mm  
正向夹持范围: 0-41mm  
反向夹持范围: 41-76mm  
钳体宽度: 75mm  
最大扭矩: 60Nm@14KN  
重量: 2.3Kg

Size: 75×100×56mm  
Forward clamping range: 0-41mm  
Reverse clamping range: 41-76mm  
Clamp body width: 75mm  
Maximum torque: 60Nm@14KN  
Weight: 2.3Kg

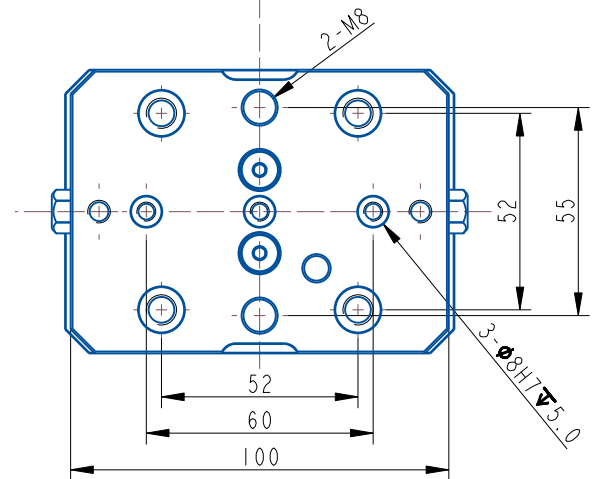
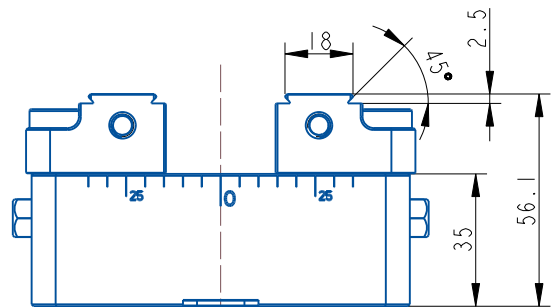

## DXQK-75150



### 描述 Describe

尺寸: 75×150×56mm  
正向夹持范围: 0-90mm  
反向夹持范围: 41-126mm  
钳体宽度: 75mm  
最大扭矩: 60Nm@14KN  
重量: 3Kg

Size: 75×150×56mm  
Forward clamping range: 0-90mm  
Reverse clamping range: 41-126mm  
Clamp body width: 75mm  
Maximum torque: 60Nm@14KN  
Weight: 3Kg

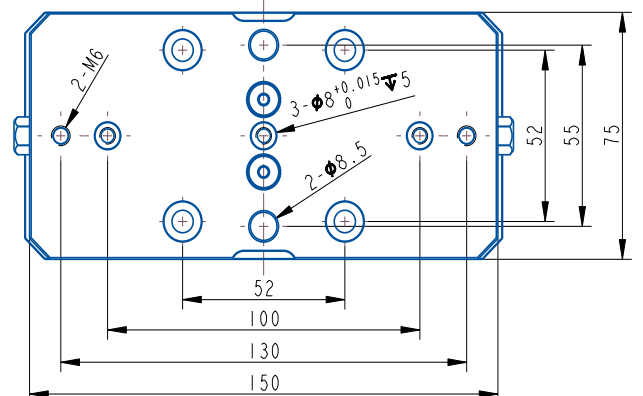
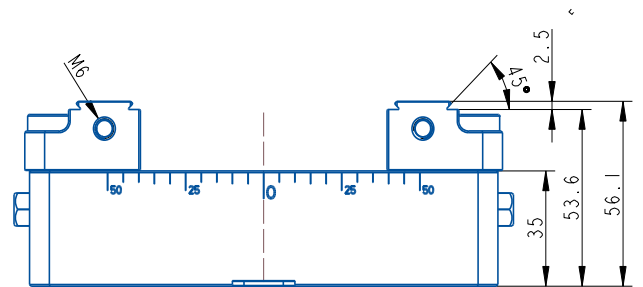

## 75系列定心虎钳 FF-75100

## Self centering vise



### 描述 Describe

尺寸: 75×100×62mm

正向夹持范围: 0-46mm

反向夹持范围: 45-76mm

钳体宽度: 75mm

最大扭矩: 60Nm@14KN

重量: 2.6Kg

**Size: 75×100×62mm**

**Forward clamping range: 0-46mm**

**Reverse clamping range: 45-76mm**

**Clamp body width: 75mm**

**Maximum torque: 60Nm@14KN**

**Weight: 2.6Kg**

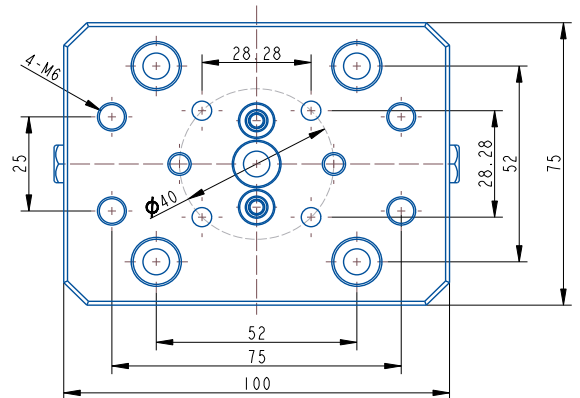
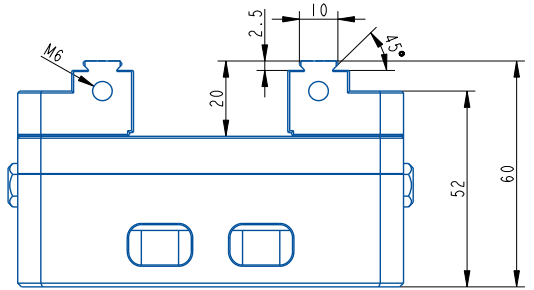

## 100系列定心虎钳 Self centering vise

FF-100150



### 描述 Describe

尺寸: 100×150×76mm

正向夹持范围: 0-80mm

反向夹持范围: 57-118mm

钳体宽度: 75mm

最大扭矩: 75Nm@20KN

重量: 5.5Kg

**Size:**

**100×150×76mm**

**Forward clamping range: 0-80mm**

**Reverse clamping range: 57-118mm**

**Clamp body width: 75mm**

**Maximum torque: 75Nm@20KN**

**Weight: 5.5Kg**

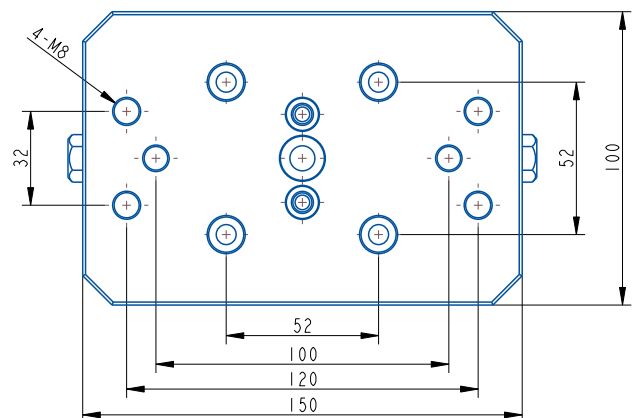
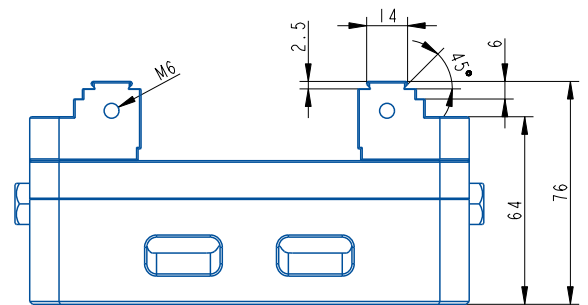

## 130系列定心虎钳

FF-130170

## Self centering vise

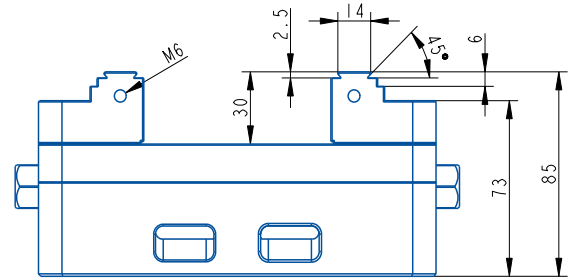

### 描述 Describe

尺寸: 130×170×85mm  
正向夹持范围: 0-86mm  
反向夹持范围: 71-152mm  
钳体宽度: 130mm  
最大扭矩: 80Nm@25KN  
重量: 9.3Kg

Size: 130×170×85mm  
Forward clamping range: 0-86mm  
Reverse clamping range: 71-152mm  
Clamp body width: 130mm  
Maximum torque: 25Nm@80KN  
Weight: 9.3Kg

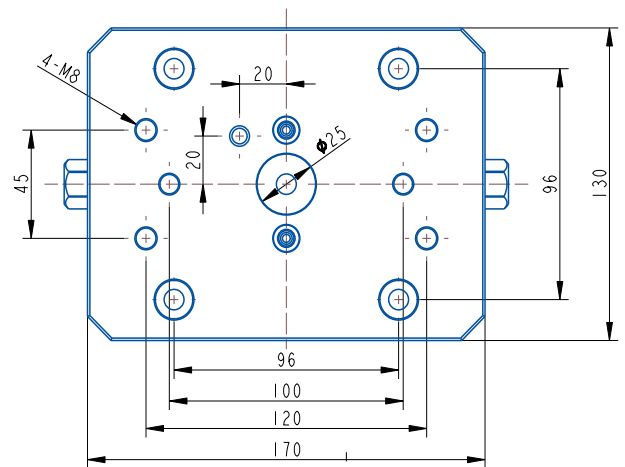

## 125系列定心虎钳

SF-125155-1

## Self centering vise

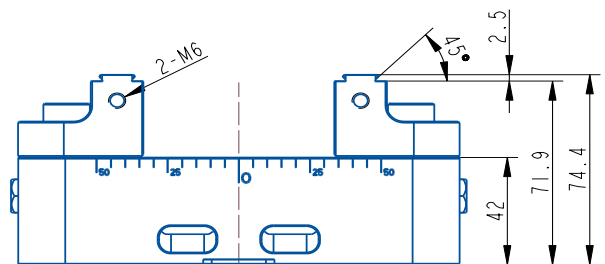

### 描述 Describe

尺寸: 125×155×74.4mm  
正向夹持范围: 0-76mm  
反向夹持范围: 56-127mm  
钳体宽度: 125mm  
最大扭矩: 75Nm@20KN  
重量: 7Kg

Size: 125×155×74.4mm  
Forward clamping range: 0-76mm  
Reverse clamping range: 56-127mm  
Clamp body width: 125mm  
Maximum torque: 75Nm@20KN  
Weight: 7Kg

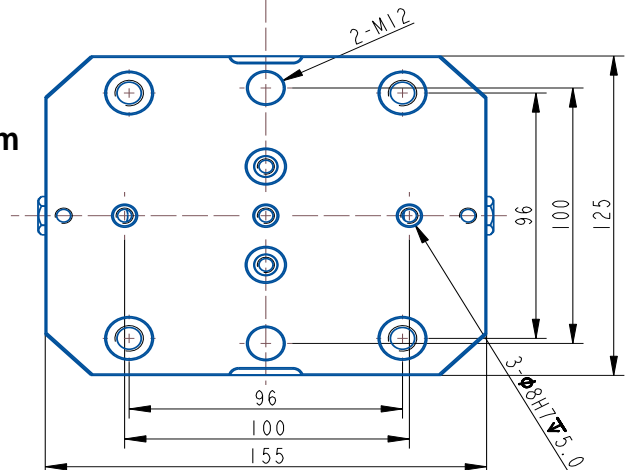

# 125系列定心虎钳

SF-125155-2

# Self centering vise

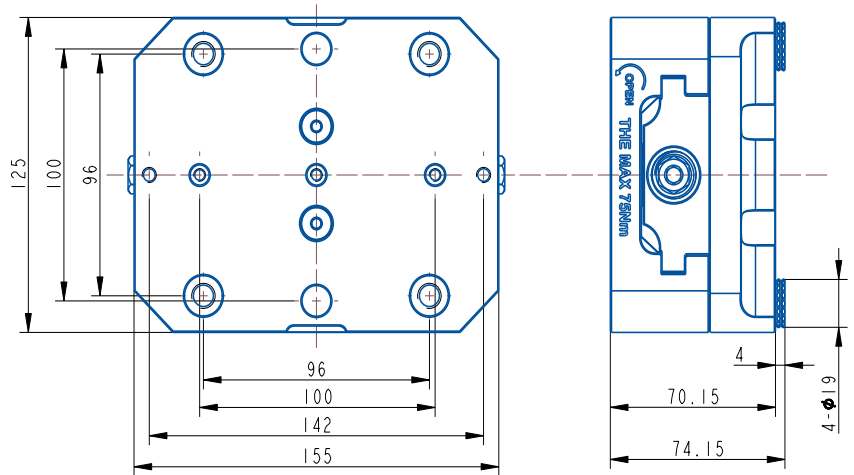

**描述 Describe**

尺寸: 125×155×74.4mm  
正向夹持范围: 0-76mm  
反向夹持范围: 56-127mm  
钳体宽度: 125mm  
最大扭矩: 75Nm@20KN  
重量: 7Kg

**Size: 125×155×74.4mm**  
**Forward clamping range: 0-76mm**  
**Reverse clamping range: 56-127mm**  
**Clamp body width: 125mm**  
**Maximum torque: 75Nm@20KN**  
**Weight: 7Kg**

## SF-155255

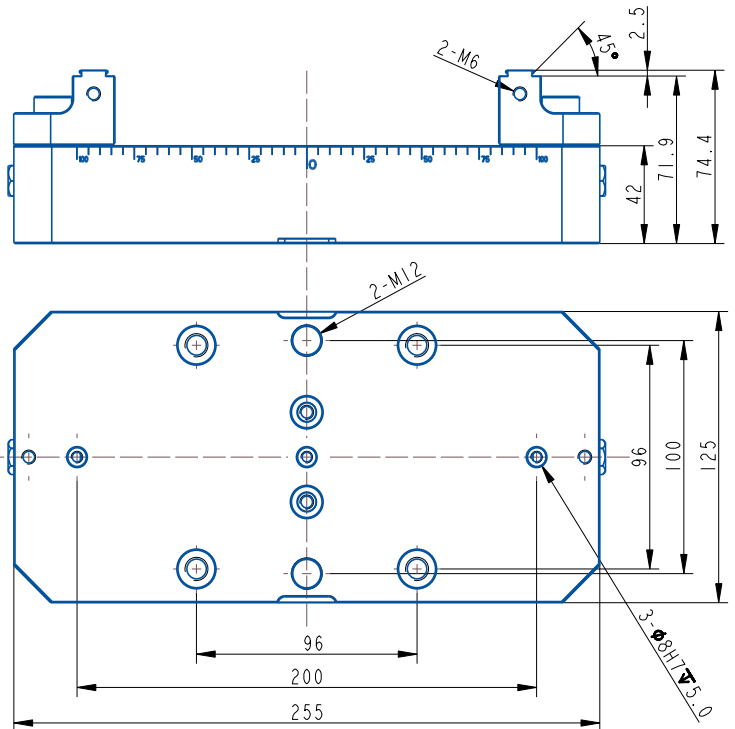

**描述 Describe**

尺寸: 125×255×74.4mm  
正向夹持范围: 0-177mm  
反向夹持范围: 56-228mm  
钳体宽度: 125mm  
最大扭矩: 75Nm@20KN  
重量: 9.8Kg

**Size: 125×255×74.4mm**  
**Forward clamping range: 0-177mm**  
**Reverse clamping range: 56-228mm**  
**Clamp body width: 125mm**  
**Maximum torque: 75Nm@20KN**  
**Weight: 9.8Kg**

# 125双工位虎钳

SFDB-125255

# Double station vise

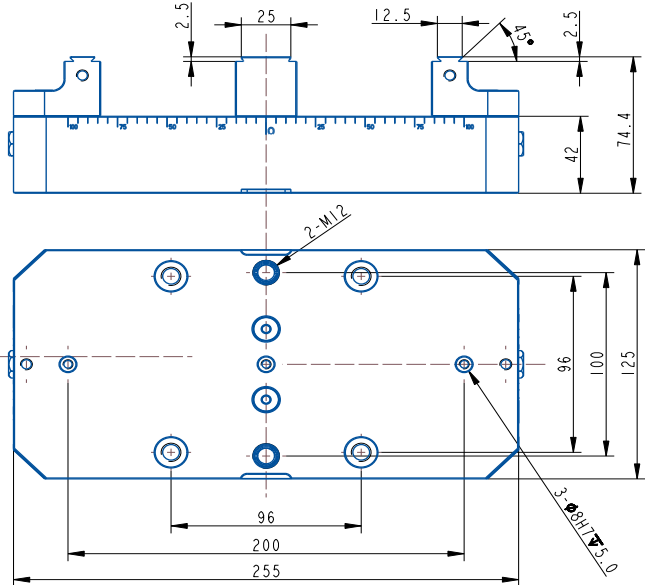

**描述 Describe**

尺寸: 125×255×74.4mm  
正向夹持范围: 0-74mm  
反向夹持范围: 32-110mm  
钳体宽度: 125mm  
最大扭矩: 75Nm@20KN  
重量: 9.8Kg

**Size: 125×255×74.4mm**  
**Forward clamping range: 0-74mm**  
**Reverse clamping range: 32-110mm**  
**Clamp body width: 125mm**  
**Maximum torque: 75Nm@20KN**  
**Weight: 9.8Kg**

# Pneumatic self-centering vise

## 气动虎钳 SLQD-0166

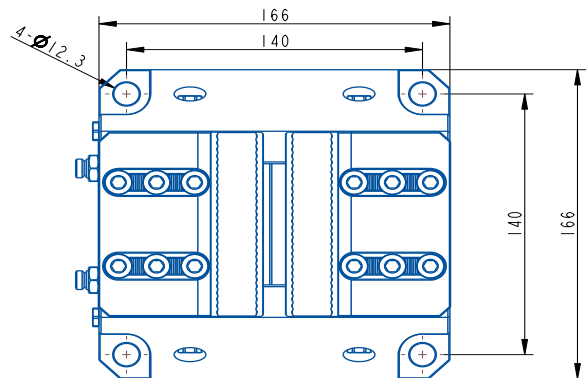

**描述 Describe**

尺寸: 166×166×138mm  
正向夹持范围: 0-50mm  
反向夹持范围: 125-160mm  
钳体宽度: 125mm  
最大扭矩:  
75Nm/7bar@20KN  
重量: 19Kg

**Size: 166×166×138mm**  
**Forward clamping range: 0-50mm**  
**Reverse clamping range: 125-160mm**  
**Clamp body width: 125mm**  
**Maximum torque: 75Nm/7bar@20KN**  
**Weight: 19Kg**

# ER型夹头 ER chuck

## ER32-52

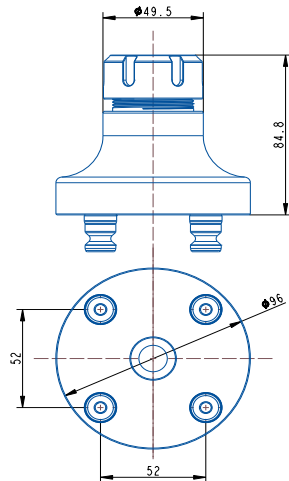

**描述 Describe**  
尺寸: D96×84.8mm  
材质: 硬化钢  
夹持范围: 2-20mm  
重量: 2.1Kg  
**Size: D96×84.8mm**  
**Material:**  
Hardened steel  
**Clamping range:**  
2-20mm  
**Weight: 2.1Kg**

## ER40-52

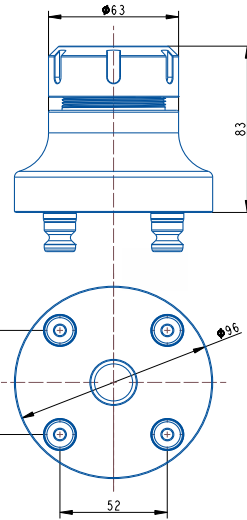

**描述 Describe**  
尺寸: D96×83mm  
材质: 硬化钢  
夹持范围: 3-26mm  
重量: 3.5Kg  
**Size: D96×83mm**  
**Material:**  
Hardened steel  
**Clamping range:**  
3-26mm  
**Weight: 3.5Kg**

# ER型夹头 ER chuck

## ER32-96

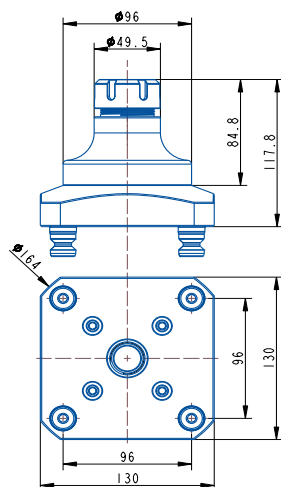

**描述 Describe**  
尺寸:  
130×130×117.8mm  
材质: 硬化钢  
夹持范围: 2-20mm  
重量: 5.8Kg  
**Size:**  
130×130×117.8mm  
**Material:**  
Hardened steel  
**Clamping range:**  
2-20mm  
**Weight: 5.8Kg**

## ER40-96

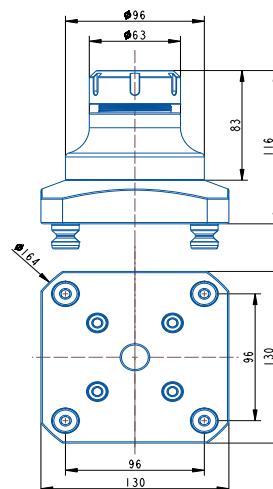

**描述 Describe**  
尺寸:  
130×130×116mm  
材质: 硬化钢  
夹持范围: 3-26mm  
重量: 6Kg  
**Size:**  
130×130×116mm  
**Material:**  
Hardened steel  
**Clamping range:**  
3-26mm  
**Weight: 6Kg**

# 卡盘 Chuck



型号 Cat. No	卡盘外径 Outside diameter of chuck	卡盘内孔 Chuck inner hole	正夹持范围 Forward clamping	反夹持范围 Reverse clamping	内撑范围 Inner brace clamping	拉丁间距 Knob distance
SFCK96-125	125	30	2.5-40	38-110	38-125	96*96
SFCK96-160	160	40	3-55	55-145	50-160	96*96
SFCK96-200	125	65	4-85	65-200	65-200	96*96
SFCK52-80	80	16	2-22	22-63	25-70	52*52
SFCK52-100	100	22	2-30	30-80	30-90	52*52
SFCK52-130	130	30	2.5-40	38-110	38-125	52*52

## 圆盘自定心虎钳 SFYP-D

## Disc Self centering vise

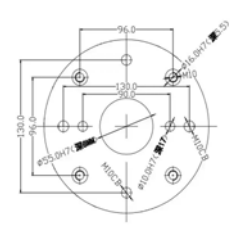
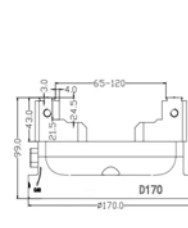
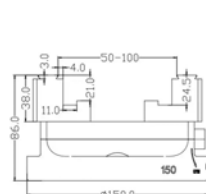
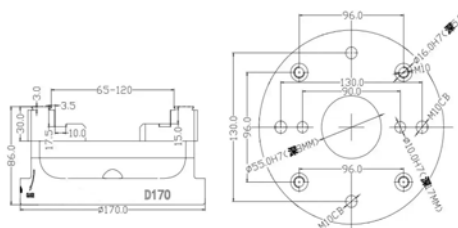
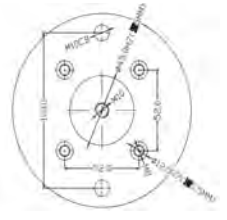
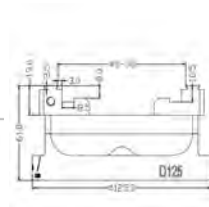
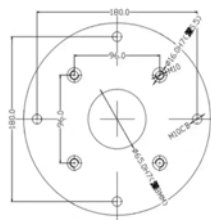
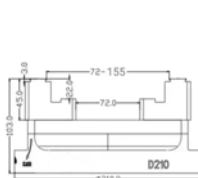
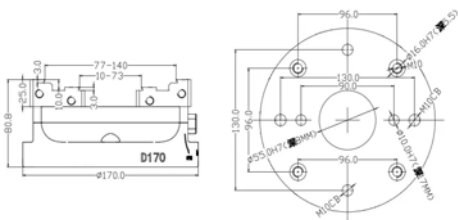
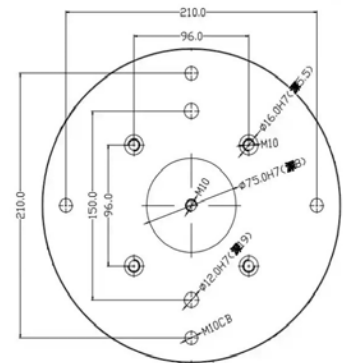
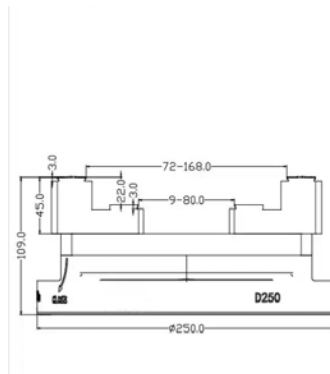



# 拉钉 Petention knob

## LD1216

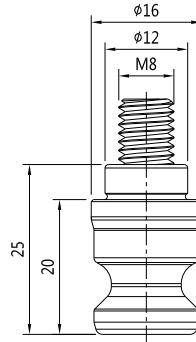

### 描述 Describe

尺寸:  $\Phi 16 \times 34\text{mm}$

材质: 硬化工具钢

重量: 0.03Kg

### Size:

$\Phi 16 \times 34\text{mm}$

### Material:

Hardened tool steel

Weight: 0.03Kg

## LD1620

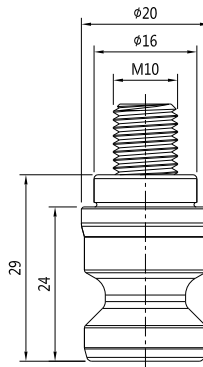

### 描述 Describe

尺寸:  $\Phi 20 \times 40\text{mm}$

材质: 硬化工具钢

重量: 0.05Kg

### Size:

$\Phi 20 \times 40\text{mm}$

### Material:

Hardened tool steel

Weight: 0.05Kg

## 安装方式

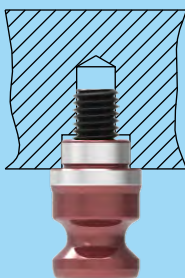

52

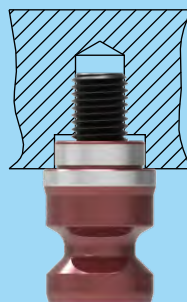

96

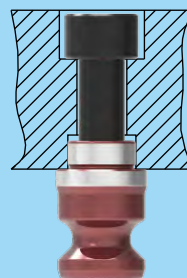

52

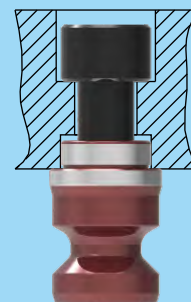

96

# L板 L board

## SL170

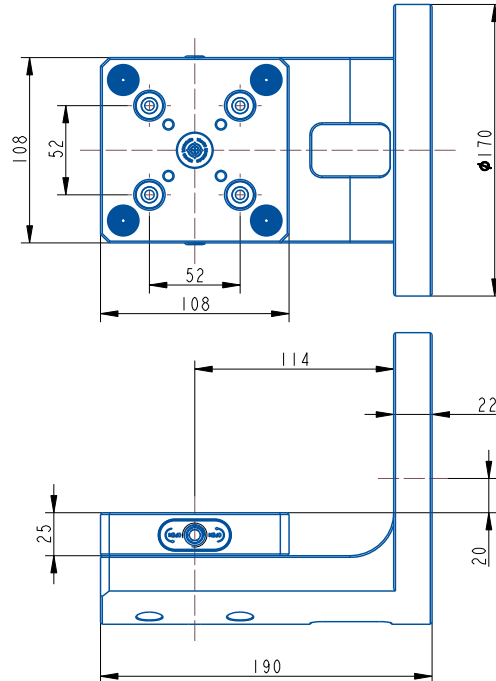

### 描述 Describe

尺寸:  $\Phi 170 \times 190 \text{mm}$   
 材质: 硬化钢+表面防锈  
 重量: 7.7Kg

**Size:**  
 $\Phi 170 \times 190 \text{mm}$   
**Material:** hardened  
 steel + surface  
 rust resistant  
**Weight:** 7.7Kg

## SL200

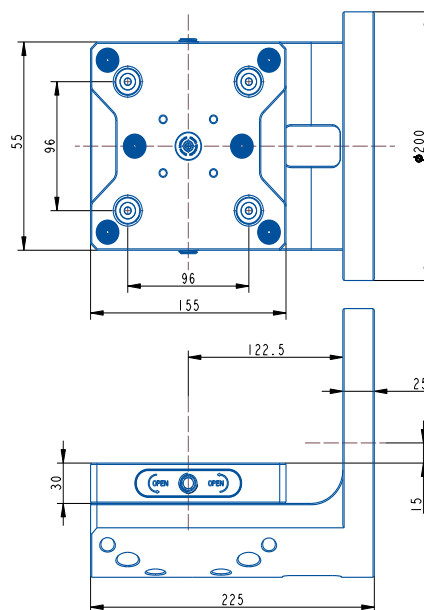

### 描述 Describe

尺寸:  $\Phi 200 \times 225 \text{mm}$   
 材质: 硬化钢+表面防锈  
 重量: 14.6Kg

**Size:**  
 $\Phi 200 \times 225 \text{mm}$   
**Material:** hardened  
 steel + surface  
 rust resistant  
**Weight:** 14.6Kg

# 附件 Appendix

## 限位器



### 描述 Describe

简单/可调节的工件限位组件  
提供快速准确的工件重新定位  
适用于所有自定心和双工位虎钳

**Simple/adjustable  
workpiece stop assembly  
Provides fast and accurate  
workpiece repositioning  
Suitable for all self-  
centering and duplex vises**

## 中心定位销



### 描述 Describe

我们的定位套件安装简单  
套件包括螺钉,T型块,定位套

为确保安装正确  
订货时请提供机床品牌型号

**Our positioning kits  
are easy to install  
Kit includes screws, T-  
block, positioning  
sleeve  
To ensure correct  
installation  
Please provide  
machine tool brand  
model when ordering**

\* 客户可自制

## 螺纹定位销



### 描述 Describe

虎钳 快换板 定位销：

LP6 - 6mm

LP8 - 8mm

LP10 - 10mm

**Vise Quick  
change plate  
Positioning pin:**

**LP6-6mm**

**LP8-8mm**

**LP10-10mm**